



High performance coaxial cable connectors are designed specifically to provide the highest quality connector-cable interface while simplifying and speeding up the attachment of connectors to air dielectric coaxial cables. Connectors are fully tested for mechanical and electrical compliance specifications. They are available in all popular cable sizes in a variety of mating interfaces. To join two cables with EIA connectors, two identical socket connectors are installed on either end of the cables to be joined, and a coupling element is used to make the connection of the center conductor. The coupling element must be ordered separately with the exception of the S-Line male versions that have a captivated coupling element. Connectors are available in sizes matching the nominal cable size. EIA connectors provide optimal power handling for the complete transmission line system.



FEATURES / BENEFITS

- Excellent gas tightness, Overpressure for increased voltage handling is maintained throughout the system
- Robust Mechanical Design, Superior and consistent performance guarantees outstanding system characteristics.
- Extremely low reflection factor, Outstanding low reflection factor improves overall system performance and margin and reduces mismatch losses
- Totally Waterproof according to IP 68, Assures safe, long term operation in the harshest of environments. System tightness doesn't have to rely on overpressure from dehydration equipment.

Technical features

GENERAL SPECIFICATIONS

Transmission Line Type		Coaxial Cable
Cable Size		7/8
Cable Type		Air Dielectric
Model Series		HCA78-50 Series
Connector Interface		1-5/8" EIA
Connector Type		RAPID FIT™
Sealing Method		Sealing compound ¹⁾
Gender		None

MECHANICAL SPECIFICATIONS

Plating Outer/Inner		Silver/Silver
Length	mm (in)	106 (4.17)
Outer Diameter	mm (in)	88.5 (3.48)
Inner Contact Attachment		Spring Finger
Outer Contact Attachment		Threaded

ACCESSORIES

Wrench size front	mm (in)	36 (1-7/16)
Wrench size rear	mm (in)	32 (1-1/4)

TESTING AND ENVIRONMENTAL

Sealing Volume, cm3 (ounces)	cm ³ (ounces)	5 (0.17)
------------------------------	--------------------------	----------



158EIA-HCA78-020

1-5/8" EIA Female Connector for 7/8" Coaxial Cable, RAPID FIT™ Sealing compound

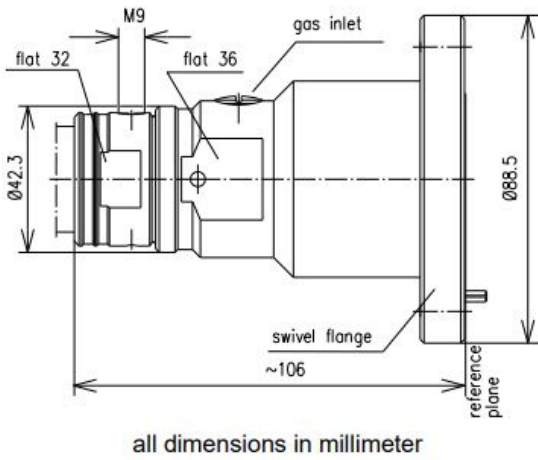

[External Document Links](#)
[Installation Instruction](#)

Notes

1) The sealing compound must be ordered separately.