

FEATURES / BENEFITS

- 2 ports / 1 cross pol system in low band (698-960MHz)
- 2 ports / 1 cross pol system in high band (1710-2690MHz)
- Integrated and field replaceable SRET
- ACU HW Version -2.02
- Compliant with AISG V2.0 and 3GPP



Technical features

ELECTRICAL SPECIFICATIONS

Electrical Specification Header		LOW BAND ARRAY (698-960 MHz) [R1]		
Frequency Band	Mhz	698-806	790-894	880-960
Gain Typical	dBi	14.3	14.5	14.9
Gain Over all Tilts	dbi	14 +/- 0.3	14.3 +/- 0.2	14.6 +/- 0.3
Azimuth Beamwidth 3dB	Deg	69.3 +/- 1.5	68.3 +/- 1.2	68.1 +/- 1.7
Elevation Beamwidth 3 dB	Deg	18.1 +/- 1.5	16.3 +/- 0.9	14.9 +/- 0.5
Cross Polar Discrimination at Boresight	dB	22.3	23.2	22.1
Cross Polar Discrimination over Sector	dB	11.6	9.8	10.8
F/B at +/-30deg Total Power	dB	23.9	23.9	24.2
Electrical Downtilt	Deg	2 to 15		
First Upper Side Lobe Suppression	dB	17	16.5	13.8
VSWR	-	1.5		
Cross Polar Isolation	dB	26		
Interband Isolation	dB	26		
Passive Intermodulation (3rd Order, 2 x 43dBm)	dBc	-153		
Maximum Effective Power per Port	Watts	350		

ELECTRICAL SPECIFICATIONS

Electrical Specification Header		HIGH BAND ARRAY (1710-2690 MHz) [Y1]				
Frequency Band	Mhz	1710-1880	1850-1990	1920-2170	2300-2400	2490-2690
Gain Typical	dBi	17.3	17.8	18	17.7	17.3
Gain Over all Tilts	dBi	16.7 +/- 0.6	17.4 +/- 0.4	17.6 +/- 0.4	16.8 +/- 0.9	16.4 +/- 0.9
Azimuth Beamwidth 3dB	Deg	61.8 +/- 6.1	66.4 +/- 3.9	66.3 +/- 4.9	68.7 +/- 5.1	60 +/- 4.1
Elevation Beamwidth 3 dB	Deg	6.2 +/- 0.6	5.6 +/- 0.4	5.2 +/- 0.5	4.8 +/- 0.4	5 +/- 0.7
Cross Polar Discrimination at Boresight	dB	17.7	17.1	17.4	24.5	19.7
Cross Polar Discrimination over Sector	dB	6.7	7.2	7	8.1	1.6
F/B at +/-30deg Total Power	dB	21.2	22.1	23	21.3	20.8
Electrical Downtilt	Deg	2 to 12				
First Upper Side Lobe Suppression	dB	18	18.8	18.9	20.7	12
VSWR	-	1.5				
Cross Polar Isolation	dB	26				
Interband Isolation	dB	26				
Passive Intermodulation (3rd Order, 2 x 43dBm)	dBc	-153				
Maximum Effective Power per Port	Watts	250				

ELECTRICAL SPECIFICATIONS

Impedance	Ohm	50
Polarization	Deg	±45°

MECHANICAL SPECIFICATIONS

Dimensions - H x W x D	mm (in)	1800 x 350 x 200 (70.9 x 13.8 x 7.9)
Weight (Antenna Only)	kg (lb)	18.2 (40.1)
Weight (Mounting Hardware only)	kg (lb)	4.5 (9.9)
Packing size- HxWxD	mm (in)	2050 x 445 x 295 (80.7 x 17.5 x 11.6)
Shipping Weight	kg (lb)	28.7 (63.3)
Connector type		4 x 4.3-10 female/bottom + 2 AISG connectors (1 male, 1 female)
Radome Material / Color		Fiberglass / Light Gray

TESTING AND ENVIRONMENTAL

Temperature Range	°C (°F)	-40 to 60 (-40 to 140)
Lightning protection		DC Ground
Survival/Rated Wind Velocity	km/h	200 (150)
Wind Load @Rated Wind Front	N	820
Wind Load @Rated Wind Side	N	397
Wind Load @Rated Wind Rear	N	947

APXVBL18B2_43-C-I20

4-Ports, X-Pol, Panel Antenna, 1.8m, 698-960/1710-2690MHz, 65deg, Integrated RET

ORDERING INFORMATION

Order No.	Configuration	Mounting Hardware	Mounting pipe Diameter	Shipping Weight
APXVBL18B2_43-C-I20	Internal RET (ACU-I20-B2)	APM50-B1	50-110 mm	28.7 Kg

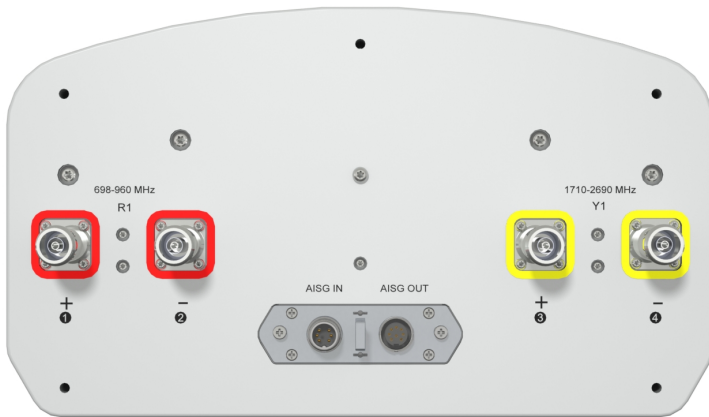

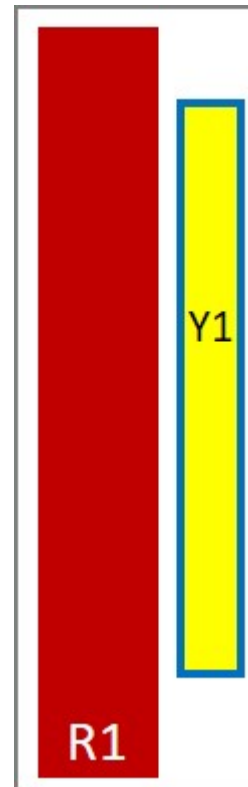
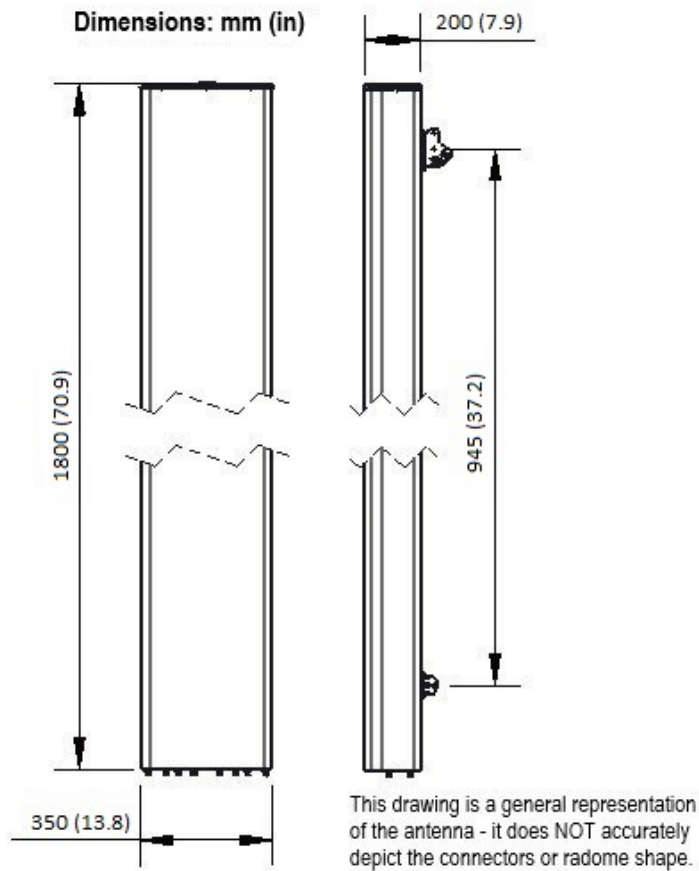

External Document Links

[APM50_Series_Installation_Instructions](#)

Notes

- All electrical parameters are compliant with BASTA NGMN 11.1 requirements.
- For additional mounting information please click "External Document Links".
- **Radiating patterns:** [Request pattern files](#)