

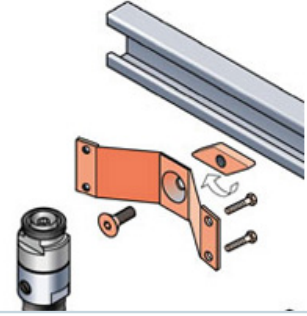

Connector grounding kit for LCF12 and SCF12 connectors

**FEATURES / BENEFITS**

These connector grounding kit provide direct connector grounding for instance an anchor bar. The assembly or disassembly is quick and easy while providing mechanical fixture and reliable ground path at the same time. All components are made of Stainless steel.



**Technical features**

**STRUCTURE**

<b>Product Line</b>			Coaxial Cable Accessories
<b>Type of Grounding Kit</b>			Connector grounding kit
<b>Transmission Line Type</b>			LCF12, HCA12-50, SCF12
<b>Cable Type</b>			Coaxial Foam Dielectric
<b>Cable Size</b>			1/2"
<b>Number of Cable / Waveguide Runs</b>			1
<b>Material</b>			Stainless Steel

**TEMPERATURE SPECIFICATIONS**

<b>Operation Temperature</b>	°C (°F)		-50 to 85 (-58 to 185 )
<b>Storage Temperature</b>	°C (°F)		-50 to 85 (-58 to 185 )

**PACKAGING INFORMATION**

<b>Package Quantity</b>			1
-------------------------	--	--	---

**External Document Links**

**Notes**

Restriction for SCF12 connectors: The connector grounding kits fit only with the 070 connector series.