



Rectangular Waveguide WR 137 H-Bend 90 degree,  
flanges CPR137G/CPR137G, f= 5.38-8.17 GHz,  
VSWR max 1.06, A=100mm (4in),  
gasket and screw kit enclosure  
body made out of brass or copper and flanges made out of brass



**FEATURES / BENEFITS**

Waveguide installation

- The rectangular waveguide component provides simple installation in particular difficult cases
- It can be installed where less space is available
- It provides outstanding electrical performance

**Technical features**

**STRUCTURE**

Type of Rectangular Waveguide Component		Bend in H-Plane
Waveguide Size IEC (EIA)		R70 (WR137)
Flange A		CPR137G
Flange B		CPR137G
Flange Finish		Brass un-plated
Package Quantity		1

**ELECTRICAL SPECIFICATIONS**

Minimum Return Loss (max. VSWR)	dB (VSWR)	30.7 (1.06)
---------------------------------	-----------	-------------

**MECHANICAL SPECIFICATIONS**

Bend/Twist	degree	90
Length	mm (in)	100 (4)

**MATERIAL**

Material		Brass
Color		White

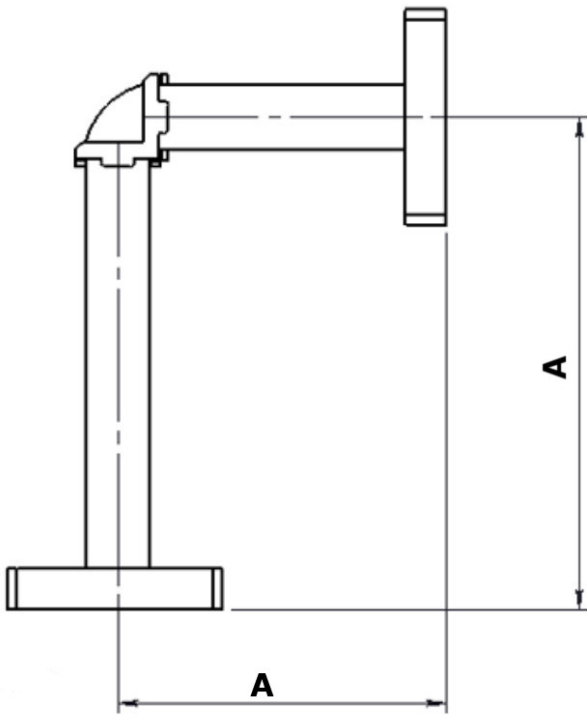

Design with casted bend



Design with arcuate waveguide bend



PRODUCT DATASHEET

**HB070-CC-1-W-010M**

90° H Plane Bend CPR137G/CPR137G

External Document Links

Notes