



Hangers for the installation of Air Dielectric Cable<sup>®</sup> cables on different supporting profiles.  
 Cable Clamp and Extended Counterbed hot-galvanized steel  
 Screw: stainless steel.

**FEATURES / BENEFITS**



picture shows the 1L4 version for illustration purpose only

**Technical features**

**GENERAL SPECIFICATIONS**

<b>Product Line</b>		Coaxial Cable Accessories
<b>Product Type</b>		Hanger
<b>Hanger Type</b>		Anchor bar 18-22mm (0.71-0.87")
<b>Transmission Line Type</b>		HCA118
<b>Cable Type</b>		Air Dielectric Coaxial Foam Dielectric

**MECHANICAL SPECIFICATIONS**

<b>Cable Size</b>		1-1/8
<b>Material</b>		Cable Clamp : hot-dip galvanized Extended Counterbed : hot-dip galvanized Screw: Stainless steel
<b>Recommended / Maximum Clamp Spacing</b>	m (ft)	0.5 / 0.9 (1.8 / 3)

**TEMPERATURE SPECIFICATIONS**

<b>Operation Temperature</b>	°C (°F)	-50 to 85 (-58 to 185 )
<b>Storage Temperature</b>	°C (°F)	-50 to 85 (-58 to 185 )

**PACKAGING INFORMATION**

<b>Package Quantity</b>		1
<b>Weight per piece</b>	kg (lb)	0.125 (0.275)



### HCH-118-1C

Cable hanger for Air Dielectric Cable

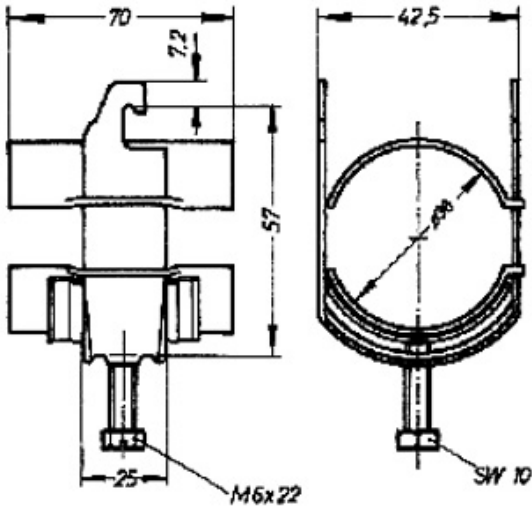

#### External Document Links

#### Notes

Hangers for anchor bar 18-22 mm (0.71-0.87")