



HCH-550-1L4

Cable hanger for Air Dielectric Cable

Hangers for the installation of Air Dielectric Cable® cables on different supporting profiles.
Cable Clamp and Extended Counterbed hot-galvanized steel
Screw: stainless steel.

FEATURES / BENEFITS



picture shows the 1L4 version for illustration purpose only

Technical features

GENERAL SPECIFICATIONS

Product Line		Coaxial Cable Accessories
Product Type		Hanger
Hanger Type		Angle iron 40mm (1.575")
Transmission Line Type		HCA550
Cable Type		Air Dielectric

MECHANICAL SPECIFICATIONS

Cable Size		5-1/2
Material		Cable Clamp : hot-dip galvanized Extended Counterbed : hot-dip galvanized Screw: Stainless steel
Recommended / Maximum Clamp Spacing	m (ft)	1 / 2 (3.3 / 6.6)

TEMPERATURE SPECIFICATIONS

Operation Temperature	°C (°F)	-50 to 85 (-58 to 185)
Storage Temperature	°C (°F)	-50 to 85 (-58 to 185)

PACKAGING INFORMATION

Package Quantity		1
------------------	--	---

HCH-550-1L4

Cable hanger for Air Dielectric Cable

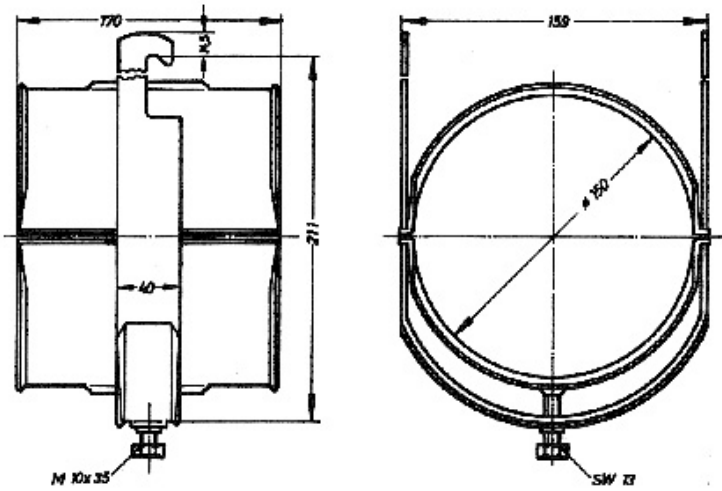

HCH Clamps available for different types of interfaces:

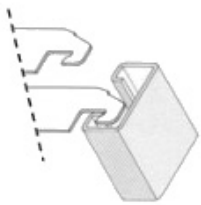

Type C
For anchor bar
(18-22mm slot)



Type L
For angle iron
(in different sizes)

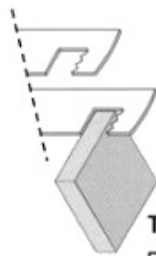

Type R
For flat iron
(6 - 12 mm)

External Document Links

Notes

Hangers for angle iron 40mm (1.575")