



# HCH-618-1C

## Cable hanger for Air Dielectric Cable

Hangers for the installation of Air Dielectric Cable® cables on different supporting profiles.  
Cable Clamp and Extended Counterbed hot-galvanized steel  
Screw: stainless steel.

### FEATURES / BENEFITS

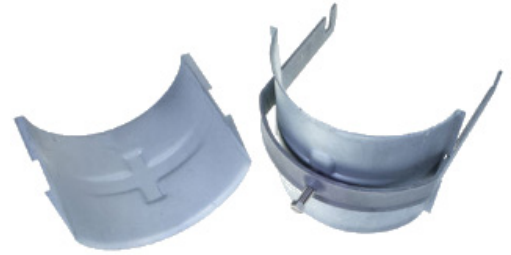

picture shows the 1L4 version for illustration purpose only

## Technical features

### GENERAL SPECIFICATIONS

Product Line		Coaxial Cable Accessories
Product Type		Hanger
Hanger Type		Anchor bar 18-22mm (0.71-0.87")
Transmission Line Type		HCA618
Cable Type		Air Dielectric

### MECHANICAL SPECIFICATIONS

Cable Size		6-1/8
Material		Cable Clamp : hot-dip galvanized Extended Counterbed : hot-dip galvanized Screw: Stainless steel
Recommended / Maximum Clamp Spacing	m (ft)	1 / 2 (3.3 / 6.6)

### TEMPERATURE SPECIFICATIONS

Operation Temperature	°C (°F)	-50 to 85 (-58 to 185 )
Storage Temperature	°C (°F)	-50 to 85 (-58 to 185 )

### PACKAGING INFORMATION

Package Quantity		1
------------------	--	---

## HCH-618-1C

Cable hanger for Air Dielectric Cable

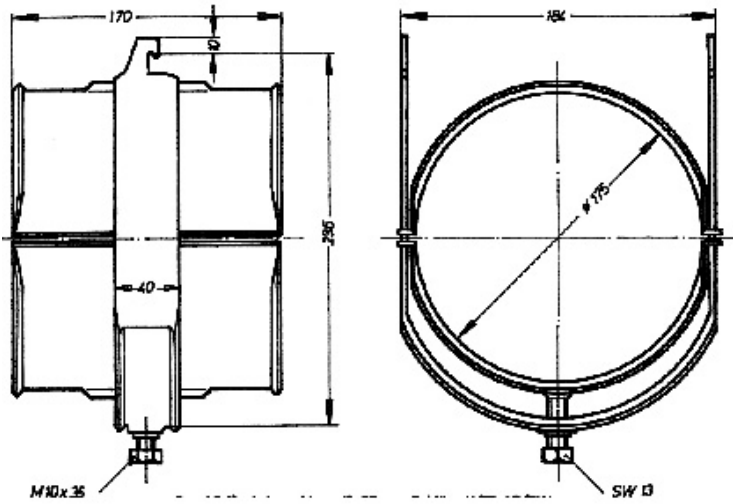

### HCH Clamps available for different types of interfaces:

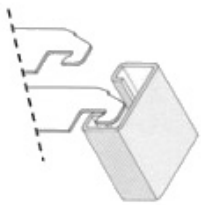

**Type C**  
For anchor bar  
(18-22mm slot)



**Type L**  
For angle iron  
(in different sizes)

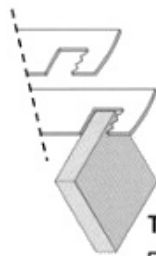

**Type R**  
For flat iron  
(6 - 12 mm)

### External Document Links

### Notes

Hangers for anchor bar 18-22 mm (0.71-0.87")