



Train and metro tunnels are usually narrowly shaped leaving only little space between the cross section of the tunnel and the volume filled by the train. Depending on the speed of the train, those turbulences create forces onto the cable, which the installation material has to withstand. For speeds above 140 km/h (86 mph) up to 350 km/h (218 mph) or even more it is recommended to use the heavy duty clamp HDC which is available for the cable sizes of 1-1/4" and 1-5/8" of all RADIAFLEX® cable with copper foil as outer conductor. The heavy duty clamp already includes the fastening mechanic for the radiating cable. Optionally, the clamp is equipped with four ports to carry additional clic clamps. Clic-clamps could be mounted for installation of fiber optic backbone cables. Suitable types are CC-12-1 and CC-78-1. They can directly be mounted without any tools and further accessories.

**FEATURES / BENEFITS**

For train speeds of up to 350 km/h (218 mph), polyamide black, fire class UL 94HB, halogen free



picture shows HDC-114

**Technical features**

**GENERAL SPECIFICATIONS**

<b>Product Line</b>		Radiating Cable Accessories
<b>Product Type</b>		Hanger
<b>Hanger Type</b>		Heavy duty clamp
<b>Transmission Line Type</b>		RLV RLF RLK RAY
<b>Cable Type</b>		Radiating Cable
<b>Color</b>		Black

**MECHANICAL SPECIFICATIONS**

<b>Cable Size</b>		1-1/4
<b>Material</b>		Polyamide

**TESTING AND ENVIRONMENTAL**

<b>Fire Class</b>		UL94 HB
-------------------	--	---------

**PACKAGING INFORMATION**

<b>Package Quantity</b>		1
-------------------------	--	---



**HDC-114-110-01**

Heavy duty clamp for RADIAFLEX<sup>®</sup> 1-1/4"

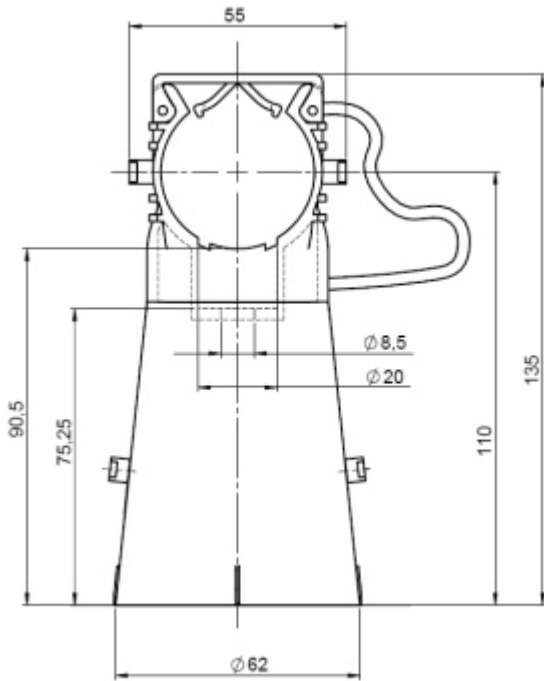

**External Document Links**

**Notes**