

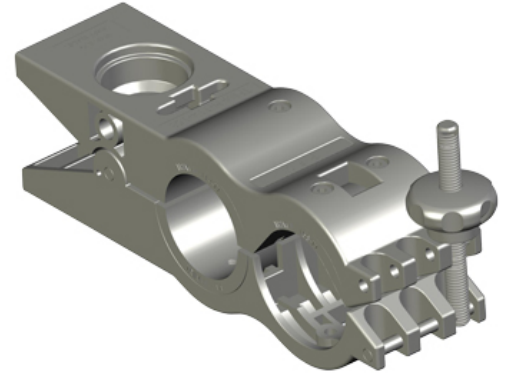

The HYBRIFLEX preparation tools are developed to make a quick and safe circular cut on HYBRIFLEX corrugated armored cables. This circular cut might be necessary in case of length adjustment. Preparation tools are available for many cable sizes.

FEATURES / BENEFITS

- **Quick and easy use** - Cut through jacket and armor by just two turns
- **No chance to damage the inner core** - The blade position is adjusted in a way that makes it impossible to cut into the inner core
- **Long lasting cutting blades**- Even if worn after many operations, they may be easily replaced
- **One Tool for mutiple cable sizes** - Two position tool, one postition for HB114 and one position for HB158 cables



External Document Links

10000031682 install. instr. trim-set-h114-158.pdf

Notes

Technical features

GENERAL SPECIFICATIONS

Cable Size		1-1/4" & 1-5/8"
Type of tool		Combination Cable Cutting Tool
Spare part / Useful Accessories		Spare Blades : TRIM-B30

MECHANICAL SPECIFICATIONS

Material		Fiberglass reinforced Polycarbonate
Weight	kg (lb)	0.386 (0.85)
Color		Red

TESTING AND ENVIRONMENTAL

Storage Temperature	°C (°F)	-40 to 85 (-40 to 185)
Operation Temperature	°C (°F)	-40 to 85 (-40 to 185)
Installation Temperature	°C (°F)	-20 to 50 (-4 to 122)
Compliance		RoHS compliant